



ENVIRONMENTAL PRODUCT DECLARATION

In accordance with ISO 14025 and EN 15804:2012+A2:2019 for:

RAILduct™

from Cubis Systems

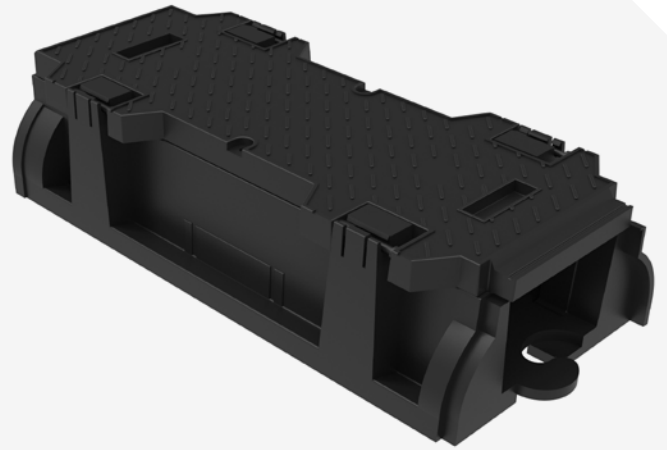

PROGRAMME:

The International EPD® System, www.environdec.com

PROGRAMME OPERATOR:

EPD International AB

EPD REGISTRATION NUMBER:

S-P-04970

PUBLICATION DATE:

2022-02-07

VALID UNTIL:

2026-12-12

An EPD should provide current information and may be updated if conditions change. The stated validity is therefore subject to the continued registration and publication at www.environdec.com



CONTENTS

ENVIRONMENTAL PRODUCT DECLARATION	4
Programme Details	4
Cubis Systems	5
Product information	6
LIFE CYCLE ASSESSMENT METHODOLOGY	8
PRODUCT CONTENT	12
ENVIRONMENTAL PERFORMANCE	14
ADDITIONAL INFORMATION	18
Product specification	18
Other additional information	19
References	19

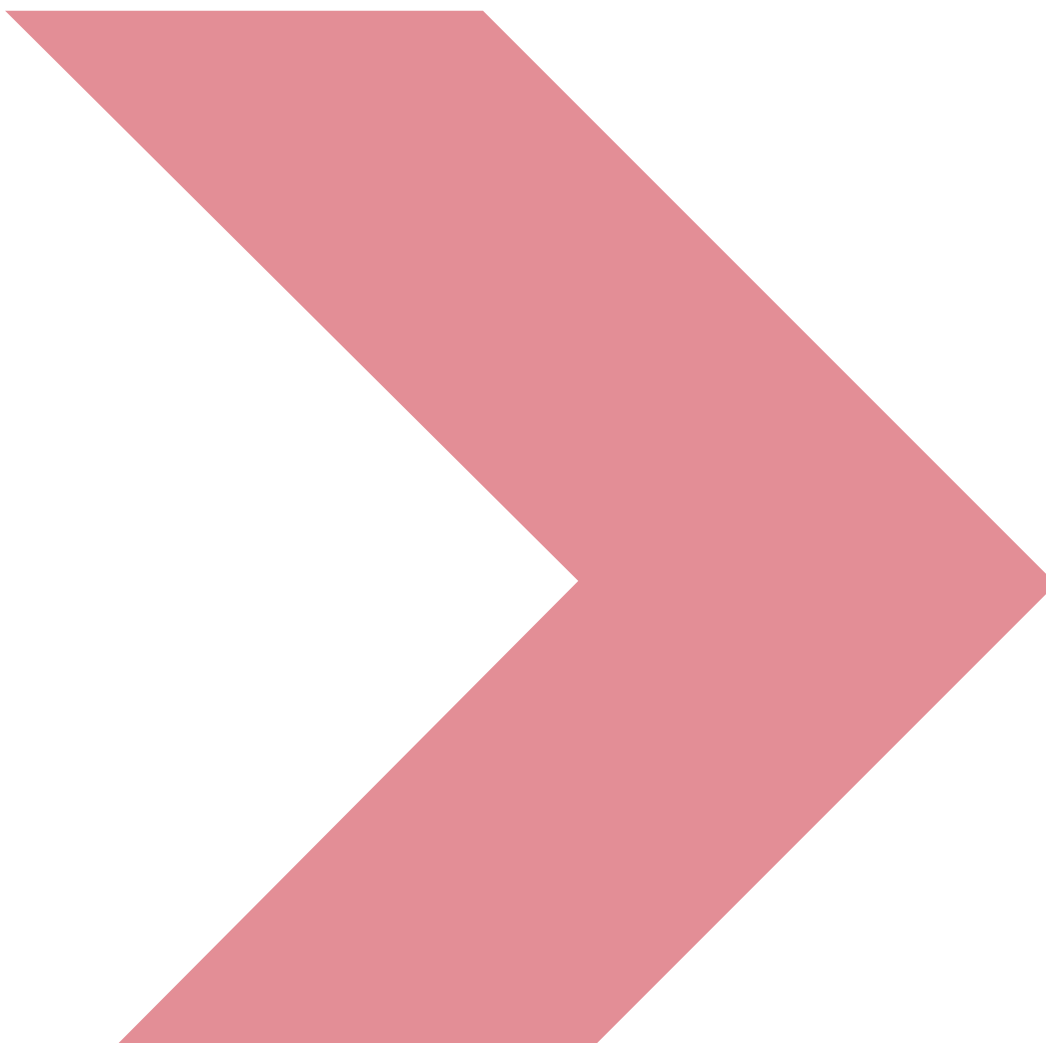



ENVIRONMENTAL PRODUCT DECLARATION

PROGRAMME DETAILS

PROGRAMME:

The International EPD® System

ADDRESS:

EPD International AB
Box 210 60
SE-100 31 Stockholm
Sweden

WEBSITE:

www.environdec.com

EMAIL:

info@environdec.com

CEN standard EN 15804 serves as the Core Product Category Rules (PCR)

Product category rules (PCR): PCR 2019:14
Construction products. Version 1.11, 2021-02-05

PCR review was conducted by: technical committee of the International EPD® System.
www.environdec.com - info@environdec.com

Independent third-party verification of the declaration and data, according to ISO 14025:2006:

EPD process certification EPD verification

Third party verifier: Chris Foster, EuGeos Srl
Approved by: The International EPD® System

Procedure for follow-up of data during EPD validity involves third party verifier:

Yes No

The EPD owner has the sole ownership, liability, and responsibility for the EPD.

EPDs within the same product category but from different programmes may not be comparable. EPDs of construction products may not be comparable if they do not comply with EN 15804. For further information about comparability, see EN 15804 and ISO 14025.

CUBIS SYSTEMS

OWNER OF THE EPD:

Cubis Systems
4 Silverwood Industrial Estate
Lurgan, Co. Armagh, BT66 6LN, UK
www.cubis-systems.com

CONTACT:

Julia McDaid
Technical Director
JMcDaid@cubis-systems.com

PRODUCT-RELATED OR MANAGEMENT SYSTEM-RELATED CERTIFICATIONS:

Cubis Systems is certified to ISO 14001:2015 Environmental Management and ISO 9001:2015 Quality Management.

NAME AND LOCATION OF PRODUCTION SITE(S):

Cubis Systems
Roscommon: Roscommon Business & Technology Park,
Gallowstown, Co. Roscommon, F42 XK30, Ireland.

DESCRIPTION OF THE ORGANISATION:

Cubis Systems is the market leader in access chambers and cable protection systems for use within global infrastructure markets. Active across seven distinct market sectors from water to telecoms, and selling to more than 30 countries, Cubis manufactures its products at sites across the UK and Ireland. Being part of CRH enables Cubis to draw down on some of the highest ethical standards and practices, whilst providing knowledge and expertise from one of the largest construction materials companies globally.

Our People

At Cubis, our ability to deliver the best for our customers rests on the commitment, talent and skills of our people. Our employees are dedicated to making the company's innovations in new designs, manufacturing techniques and materials work consistently for customers across the world.

With customer satisfaction strongly embedded in our company culture, we build close relationships in key industries internationally to ensure Cubis products solve real-world issues in the building of underground infrastructure networks.

Our Products

Cubis products deliver high-quality modern solutions that replace conventional construction materials like bricks and concrete. Our strong, lightweight modular products incorporate intelligent design features and can be installed much faster than traditional methods, saving customers time and money.

All our products have been designed to maximise structural strength using the optimum amount of material thus eliminating any unnecessary weight or waste. By re-using materials, where possible, that would otherwise be disposed of as a waste, we not only divert them from waste streams, but also reduce the carbon footprint of our products and promote resource efficiency. The design and adaptability of our products also future proofs the system allowing for expanded capacity without a need for product replacement. Lightweight product parts remove the need for heavy lifting equipment, reducing the energy demand during installation.

Our Responsibilities

Whether in the workplace, the marketplace, the community or the environment, corporate responsibility matters to Cubis and we show it through the way we work and behave.

At Cubis Systems, we use a variety of materials to manufacture our products. Our goal is to create a closed loop recycling system and a circular economy. We can achieve this by using as much recycled material as we can in our manufacturing process and by ensuring our products are either recyclable or reusable wherever possible.

Health and Safety is integrated into the fabric of the company's business and operations. We fully support the right of every employee to work in an environment that means we all go home safely at the end of each day. We also take our responsibility to the environment seriously. We work hard to address the challenges of climate change both through product design and careful management of our production processes.

PRODUCT INFORMATION

PRODUCT NAME:

RAILduct™

PRODUCT IDENTIFICATION:

Cable trough system in High Density Polyethylene (HDPE)

UN CPC CODE:

CPC 3699 Articles of plastics n.e.c.

PRODUCT DESCRIPTION:

Cubis' CABLEprotect range is central to our integrated system approach to cable protection and chamber access. Incredibly strong yet lightweight, these modern protection systems are the best and most cost-effective alternative to traditional cable ducting methods on the global market today.

Cubis' range of cable troughing products feature innovative and lightweight features, that provide a modern solution for troughing systems predominately used within the rail industries.

RAILDUCT™

The modern, lightweight alternative to concrete cable troughing RAILduct™ cable protection system is a HDPE cable trough system. Weighing under 15kg but capable of taking loads imparted by vehicular traffic, RAILduct™ offers significant advantages in health and safety, speed and flexibility during installation.

QUICK ASSEMBLY

RAILduct™ offers a hook, twist and lock interlocking mechanism allowing fast laying of multiple units.

OPTIONAL WATER DRAINAGE

Moulded slots within the base of the RAILduct™ unit allow for natural drainage of water into the ground below.

ALLOWS FOR THERMAL EXPANSION

Allows for thermal expansion of +/-6mm. Shroud prevents vertical movement and allows the unit to expand and contract in accordance with ambient temperature changes.

FLEXIBLE

RAILduct™ is built with 3° of flexibility in the interlocking connection to match bends in the track. For more extreme bends, vertical and horizontal bends can be supplied.

LIGHTWEIGHT

Weighing under 15kg the RAILduct™ offers significant health and safety advantages over traditional concrete troughing systems that can weigh over 90kg. RAILduct™ is suitable for single person lift and install, enabling compliance with manual handling regulations. Being lightweight and easy to deploy results in considerable project time and cost savings.

TECHNICAL INFORMATION

Further technical information including, product data sheets, technical drawings, BIM models, product brochures, installation guides, certifications and accreditations is available on the Cubis Systems website: www.cubis-systems.com/uk/technical-area/.



LIFE CYCLE ASSESSMENT METHODOLOGY

LCA INFORMATION

DECLARED UNIT:

1 kg of RAILduct™

TIME REPRESENTATIVENESS:

2019

DATABASE USED:

Ecoinvent 3.6

LCA SOFTWARE USED:

Simapro 9.1

LCA PRACTITIONER:

Studio Fieschi & soci Srl
C.so Vittorio Emanuele II, 18 10123 Torino, IT
www.studiofieschi.it



DESCRIPTION OF SYSTEM BOUNDARIES:

Cradle-to-gate with options (Modules A4–A5), modules C1–C4 and module D. System boundaries include:

- A1: Raw material extraction and processing, processing of secondary material input, production of energy used in manufacturing processes (A3);
- A2: Transport of raw materials and secondary material inputs to Cubis Systems sites and internal transport;
- A3: Manufacturing of the construction product and packaging, including water use, emissions to air and water discharges, waste disposal;
- A4: Transport to the installation site;
- A5: Installation;
- C1: De-construction and demolition;
- C2: Transport to waste processing;
- C3: Waste processing for reuse, recovery and/or recycling;
- C4: Final disposal;
- D: Estimate of the potential benefits and/or impacts in case the products under study were reused, recycled or recovered.

The system boundaries do not include:

- Input and output flows related to personnel (e.g. energy used in head offices and sales offices, transport of employees to and from workplace, water use for toilets, etc);
- Input and output flows related to production and maintenance of equipment.

System diagram

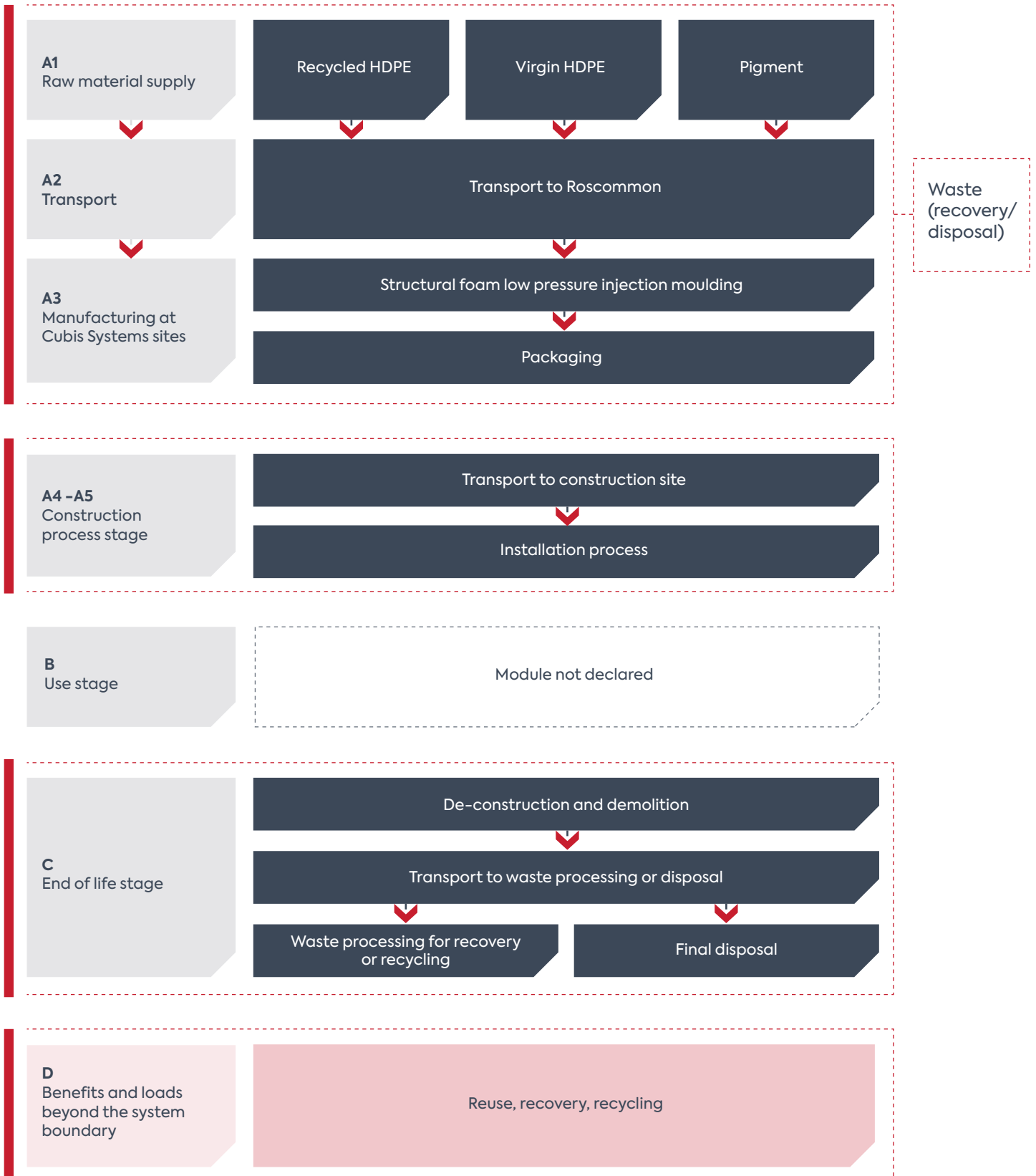

CUT-OFF:

The following cut-offs were applied: polyester strapping used for packaging.

ALLOCATION RULES:

Input and output flows were allocated based on the mass of products and co-products.

IMPACT ASSESSMENT:

Inventory indicators relating to the use of renewable and non-renewable secondary fuels, as well as energy exported in output flows, have been assumed 0, as these flows are not significant for the products under analysis and their modelling would be subject to a high level of uncertainty.

PRODUCTION PROCESS (A1-A3):

RAILduct is a cable trough system produced in HDPE, 90% recycled and consists of one meter long sections.

RAILduct is manufactured in Roscommon using a low-pressure injection moulding process

PACKAGING:

The product is packed on wooden pallets. It is assumed that pallets are reused 25 times [9].

ENERGY MIX:

Roscommon site uses electricity, 42.9% from renewable sources. The GWP-GHG of the electric mix used is 267g CO₂eq./kWh.

TRANSPORT AND INSTALLATION (A4 – A5):

➤ Module A4: Transportation impacts occurred from delivering the final products to the construction site, covering direct fuel exhaust emissions, environmental impacts of fuel production, as well as related infrastructure emissions. The distribution scenario was modelled according to logistics data provided by Cubis Systems and using Ecoinvent datasets for freight transport: truck > 32t (diesel) for road transport and ship (diesel) for extra-European transportation:

- Vehicle type: truck > 32t (diesel) for road transport and ship (diesel) for extra-European transportation;
- Weighted average distance: 550 km by truck, 379 km by ship;
- Capacity utilisation: according to Ecoinvent datasets for freight transport in Europe;
- Bulk density of transported products: trucks are loaded to their maximum mass capacity;
- Volume capacity utilisation factor: <1.

➤ Module A5: RAILduct is hand laid and does not require machinery for its installation. The installation of RAILduct requires the removal of excess soil by truck >32t (0.0078 t/kg, distance 10 km one way), assumed 90% to recovery and 10% destined to landfill [10]. Waste materials generated by the product's installation: packaging, wooden pallet, to energy recovery (assumed 50 km to recovery facility): 0,0092 kg.

END OF LIFE SCENARIO (C1-C4):

- Collection process: 1 kg of waste collected separately.
- Recovery system: 0.24 kg for recycling; 0.49 kg for energy recovery.
- Disposal: 0.27 kg of HDPE cable duct for final disposal.
- Assumptions for scenario development:
 - Module C1: not relevant (as for installation, the removal of RAILduct does not require the use of machinery);
 - Module C2: a distance of 50 km is assumed for the transport of materials to disposal, distributed as 63% by truck and 37% by train [8];
 - Modules C3 / C4: the following EoL scenario for HDPE was set [12]:
 - 24% to recycling; 49% to energy recovery; 27% to landfill
 - for HDPE to reach the End-of-Waste state, sorting processes must be carried out, involving the use of 0.017 kWh/kg of electricity, 0.000086 MJ/kg of natural gas, 0.069 MJ/kg of diesel and 0.018 MJ/kg of LPG.

Modules declared, geographical scope, share of specific data (in GWP-GHG indicator) and data variation:

Stages		Module	Modules declared	Geography	Specific data used	Variation – products	Variation – sites
Product stage	Raw material supply	A1	X	EU	>90%	Not relevant	Not relevant
	Transport	A2	X	EU			
	Manufacturing	A3	X	UK			
Construction process stage	Transport	A4	X	Global			
	Construction installation	A5	X	Global			
Use stage	Use	B1	ND	-	-	-	-
	Maintenance	B2	ND	-	-	-	-
	Repair	B3	ND	-	-	-	-
	Replacement	B4	ND	-	-	-	-
	Refurbishment	B5	ND	-	-	-	-
	Operational energy use	B6	ND	-	-	-	-
	Operational water use	B7	ND	-	-	-	-
End of life stage	De-construction demolition	C1	X	Global	-	-	-
	Transport	C2	X	Global	-	-	-
	Waste processing	C3	X	Global	-	-	-
	Disposal	C4	X	Global	-	-	-
Resource recovery stage	Reuse-Recovery-Recycling-potential	D	X	Global	-	-	-

PRODUCT CONTENT

Product components	Weight, kg	Post-consumer material, weight-%	Renewable material, weight-%
Virgin HDPE	0.067	0%	0
Recycled HDPE	0.89	100%	0
Pigment	0.038	0%	
TOTAL	1.0	89%	0
Packaging materials	Weight, kg	Weight-% (versus the product)	
Pallet (wood)	0.0092	0.92%	
TOTAL	0.0092	0.92%	

The product does not contain dangerous substances from the candidate list of Substances of Very High Concern (SVHC) for Authorisation.



ENVIRONMENTAL PERFORMANCE

Potential environmental impact – mandatory indicators according to EN 15804

Results per 1 kg of RAILduct									
INDICATOR	UNIT	Tot.A1-A3	A4	A5	C1	C2	C3	C4	D
GWP-total	kg CO ₂ eq.	1.29E+00	8.03E-02	7.10E-03	0.00E+00	3.67E-03	1.10E-02	3.08E-02	0.00E+00
GWP-fossil	kg CO ₂ eq.	1.29E+00	8.03E-02	7.10E-03	0.00E+00	3.66E-03	1.09E-02	3.08E-02	0.00E+00
GWP-biogenic**	kg CO ₂ eq.	4.60E-03	3.97E-05	2.94E-06	0.00E+00	4.54E-06	3.84E-05	2.75E-06	0.00E+00
GWP-luluc	kg CO ₂ eq.	4.27E-04	5.20E-05	2.07E-06	0.00E+00	2.28E-06	1.25E-05	6.01E-07	0.00E+00
ODP	kg CFC 11 eq.	1.19E-07	1.79E-08	1.67E-09	0.00E+00	7.52E-10	1.66E-09	8.43E-10	0.00E+00
AP	mol H ⁺ eq.	3.88E-03	4.64E-04	2.99E-05	0.00E+00	1.68E-05	8.04E-05	2.09E-05	0.00E+00
EP-freshwater	kg P eq.	2.99E-05	6.99E-07	5.42E-08	0.00E+00	7.71E-08	5.70E-07	2.76E-08	0.00E+00
EP-freshwater	kg PO ₄ ³⁻ eq.	9.16E-05	2.14E-06	1.66E-07	0.00E+00	2.36E-07	1.75E-06	8.47E-08	0.00E+00
EP-marine	kg N eq.	8.57E-04	1.62E-04	8.98E-06	0.00E+00	4.63E-06	2.58E-05	3.96E-05	0.00E+00
EP-terrestrial	mol N eq.	9.58E-03	1.78E-03	9.94E-05	0.00E+00	5.16E-05	2.89E-04	8.32E-05	0.00E+00
POCP	kg NMVOC eq.	3.15E-03	5.15E-04	3.19E-05	0.00E+00	1.61E-05	7.90E-05	3.03E-05	0.00E+00
ADP-minerals & metals*	kg Sb eq.	1.22E-05	1.21E-06	1.21E-07	0.00E+00	5.69E-08	2.49E-08	2.04E-08	0.00E+00
ADP-fossil*	MJ	2.13E+01	1.20E+00	1.10E-01	0.00E+00	5.76E-02	1.86E-01	6.20E-02	0.00E+00
WDP	m ³	3.07E-01	4.01E-03	3.66E-04	0.00E+00	2.99E-04	1.26E-03	2.87E-04	0.00E+00
Acronyms	GWP-fossil = Global Warming Potential fossil fuels; GWP-biogenic = Global Warming Potential biogenic; GWP-luluc = Global Warming Potential land use and land use change; ODP = Depletion potential of the stratospheric ozone layer; AP = Acidification potential, Accumulated Exceedance; EP-freshwater = Eutrophication potential, fraction of nutrients reaching freshwater end compartment; EP-marine = Eutrophication potential, fraction of nutrients reaching marine end compartment; EP-terrestrial = Eutrophication potential, Accumulated Exceedance; POCP = Formation potential of tropospheric ozone; ADP-minerals&metals = Abiotic depletion potential for non-fossil resources; ADP-fossil = Abiotic depletion for fossil resources potential; WDP = Water (user) deprivation potential, deprivation-weighted water consumption								

* Disclaimer: The results of this environmental impact indicator shall be used with care as the uncertainties of these results are high or as there is limited experience with the indicator. ** Disclaimer: As there is no significant contribution of biogenic carbon in the product, the balance of CO₂ from biogenic origin entering and leaving the system was assumed to be neutral.

Potential environmental impact – additional mandatory and voluntary indicators

Results per 1 kg of RAILduct									
INDICATOR	UNIT	Tot.A1-A3	A4	A5	C1	C2	C3	C4	D
GWP-GHG ¹	kg CO ₂ eq.	1.27E+00	7.96E-02	7.04E-03	0.00E+00	3.63E-03	1.08E-02	2.64E-02	0.00E+00

Use of resources

Results per 1 kg of RAILduct									
INDICATOR	UNIT	Tot.A1-A3	A4	A5	C1	C2	C3	C4	D
PERE	MJ	2.34E+00	1.81E-02	1.39E-03	0.00E+00	2.26E-03	1.87E-02	2.87E-03	0.00E+00
PERM	MJ	1.56E-01	0.00E+00	0.00E+00	0.00E+00	0.00E+00	0.00E+00	0.00E+00	0.00E+00
PERT	MJ	2.50E+00	1.81E-02	1.39E-03	0.00E+00	2.26E-03	1.87E-02	2.87E-03	0.00E+00
PENRE	MJ	1.88E+01	1.20E+00	1.10E-01	0.00E+00	5.76E-02	1.86E-01	6.20E-02	0.00E+00
PENRM	MJ	2.47E+00	0.00E+00	0.00E+00	0.00E+00	0.00E+00	0.00E+00	0.00E+00	0.00E+00
PENRT	MJ	2.13E+01	1.20E+00	1.10E-01	0.00E+00	5.76E-02	1.86E-01	6.20E-02	0.00E+00
SM	kg	9.09E-01	0.00E+00	0.00E+00	0.00E+00	0.00E+00	0.00E+00	0.00E+00	0.00E+00
RSF	MJ	0.00E+00	0.00E+00	0.00E+00	0.00E+00	0.00E+00	0.00E+00	0.00E+00	0.00E+00
NRSF	MJ	0.00E+00	0.00E+00	0.00E+00	0.00E+00	0.00E+00	0.00E+00	0.00E+00	0.00E+00
FW	m ³	7.55E-03	1.52E-04	1.28E-05	0.00E+00	1.41E-05	9.35E-05	7.73E-05	0.00E+00
Acronyms	PERE = Use of renewable primary energy excluding renewable primary energy resources used as raw materials; PERM = Use of renewable primary energy resources used as raw materials; PERT = Total use of renewable primary energy resources; PENRE = Use of non-renewable primary energy excluding non-renewable primary energy resources used as raw materials; PENRM = Use of non-renewable primary energy resources used as raw materials; PENRT = Total use of non-renewable primary energy re-sources; SM = Use of secondary material; RSF = Use of renewable secondary fuels; NRSF = Use of non-renewable secondary fuels; FW = Use of net fresh water								

¹ The indicator includes all greenhouse gases included in GWP-total but excludes biogenic carbon dioxide uptake and emissions and biogenic carbon stored in the product. This indicator is thus almost equal to the GWP indicator originally defined in EN 15804:2012+A1:2013.

Waste production and output flows

Waste production

Results per 1 kg of RAILduct									
INDICATOR	UNIT	Tot.A1-A3	A4	A5	C1	C2	C3	C4	D
Hazardous waste disposed	kg	0.00E+00	0.00E+00	0.00E+00	0.00E+00	0.00E+00	0.00E+00	0.00E+00	0.00E+00
Non-hazardous waste disposed	kg	7.09E-03	0.00E+00	0.00E+00	0.00E+00	0.00E+00	0.00E+00	2.70E-01	0.00E+00
Radioactive waste disposed	kg	7.41E-05	8.16E-06	7.54E-07	0.00E+00	3.83E-07	1.31E-06	4.09E-07	0.00E+00

Output flows

Results per 1 kg of RAILduct									
INDICATOR	UNIT	Tot.A1-A3	A4	A5	C1	C2	C3	C4	D
Components for re-use	kg	0.00E+00	0.00E+00	0.00E+00	0.00E+00	0.00E+00	0.00E+00	0.00E+00	0.00E+00
Material for recycling	kg	0.00E+00	0.00E+00	0.00E+00	0.00E+00	0.00E+00	2.40E-01	0.00E+00	0.00E+00
Materials for energy recovery	kg	4.19E-04	0.00E+00	9.16E-03	0.00E+00	0.00E+00	4.90E-01	0.00E+00	0.00E+00
Exported energy, electricity	MJ	0.00E+00	0.00E+00	0.00E+00	0.00E+00	0.00E+00	0.00E+00	0.00E+00	0.00E+00
Exported energy, thermal	MJ	0.00E+00	0.00E+00	0.00E+00	0.00E+00	0.00E+00	0.00E+00	0.00E+00	0.00E+00

Information on biogenic carbon content

Results per functional or declared unit		
BIOGENIC CARBON CONTENT	UNIT	QUANTITY
Biogenic carbon content in product	kg C	0
Biogenic carbon content in packaging	kg C	0.0046

Note: 1 kg biogenic carbon is equivalent to 44/12 kg CO₂.



ADDITIONAL INFORMATION

PRODUCT SPECIFICATION

RAILduct™

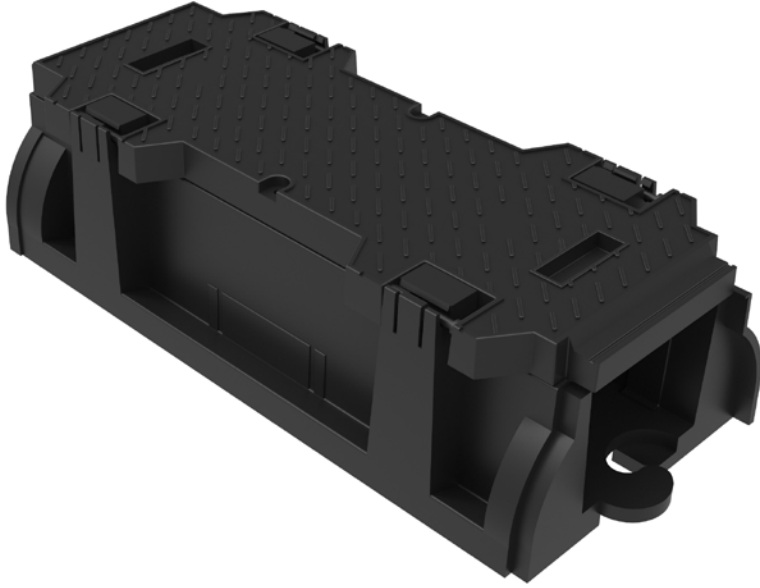

LENGTH (mm)	WEIGHT (kg)
1000	14.4

OTHER ADDITIONAL INFORMATION

Cubis Systems is a member of Composites UK. Within this association, CUBIS participate in the Composites UK Sustainability & Construction Sub-Groups with involvement in research projects to expand the recycling knowledge and capabilities of composites.

For further information and for a copy of the Cubis Sustainability Report please see our website: www.cubis-systems.com

REFERENCES

- 1 General Programme Instructions of the International EPD®System. Version 3.01.
- 2 PCR 2019:14. Construction products. Version 1.11
- 3 EN 15804:2012 + A2:2019 Sustainability of construction works – Environmental product declarations – Core rules for the product category of construction products
- 4 ISO 14025:2010 Environmental labels and declarations – Type III environmental declarations – Principles and procedures
- 5 ISO 14040:2006 Environmental management – Life cycle assessment – Principles and framework
- 6 ISO 14044:2006 Environmental management – Life cycle assessment - Requirements and guidelines
- 7 Studio Fieschi & soci Srl, Life Cycle Assessment (LCA) of Cubis Systems' products: STAKKAbOX ULTIMA/ ULTIMA Connect, STAKKAbOX Fortress, STAKKAbOX Modula, RapidSTACK, MONObOX Carson, AX-S Covers, CABLEprotect PROtrough and MMtrough, CABLEprotect RAILduct, CABLEprotect MULTIduct.
- 8 Ecoinvent 3.6
- 9 European Commission, 2018, Product Environmental Footprint Category Rules Guidance, Version 6.3
- 10 Eurostat, 2018, Recovery rate of construction and demolition waste.
- 11 Gervasio, H., Dimova, S., 2018, Model for Life Cycle Assessment (LCA) of buildings, EC JRC technical reports
- 12 Plastics Europe, 2018, Overview plastic waste from building & construction by polymer type and by recycling.



ENVIRONMENTAL PRODUCT DECLARATION

RAILduct™

CONTACT US

Head Office: 4 Silverwood
Industrial Estate, Lurgan,
Co. Armagh, BT66 6LN,
Northern Ireland

Telephone: +44 (0)28 38 313 100
Email: info@cubis-systems.com

www.cubis-systems.com

DRIVEN BY INNOVATION

Cubis Systems is Europe's leading manufacturer of network access chamber and ducting systems, used in the construction of infrastructure networks for rail, telecoms, water, construction and energy markets.

Cubis has developed an innovative approach in a traditional industry. This has been achieved by developing quality products which replace traditional construction materials, like bricks and concrete, with lightweight plastics incorporating intelligent design features. These can then be installed faster and ultimately save our customers both time and money.

Cubis manufactures preformed network access chamber systems STAKKAbOX™, AX-S™ access covers, MULTIduct™ multiple duct system and PROtrough cable trough at its manufacturing sites throughout the UK and Ireland these products are exported to more than 30 countries throughout the world.

At Cubis we pride ourselves on delivering technical customer support, new innovation, product quality and the highest levels of customer satisfaction.